



What Do You Put in the Light?

A Therapeutic Model developed by Phillip Bass of Trinitas Services

Reflect. Before responding, sit with these questions:

- Where do you feel most comfortable being your true self?
- Where in your life do you feel staged — free to be seen?
- Who is your safe audience?

Define where you feel staged in your life. What do you put into the light?

What I put in the light:

- 1.
- 2.
- 3.
- 4.
- 5.
- 6.
- 7.
- 8.
- 9.
- 10.

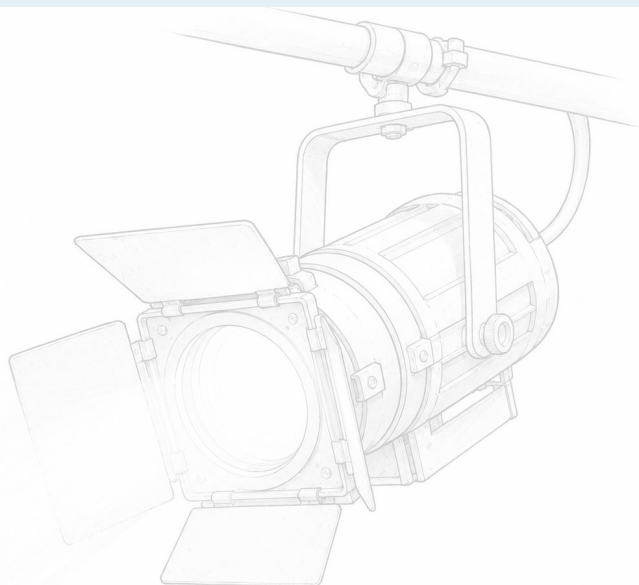

"We all want the freedom to be ourselves, yet we are most afraid of being ourselves."

www.nurtureplaystructure.com